

Carton Contents

- Amplifier unit
- Mains power cable
- Input connector x 2 or 4
- GPIO socket connector
- Output connector x 2 or 4
- Adhesive rubber feet x 4
- Document pack
- Rack Ears (PowerZone 1004)

Support

- A full user manual that includes information on **installation**, **mounting accessories**, use of **GPIO** functions and amplifier **operation** is available online: www.blaze-audio.com

Connections

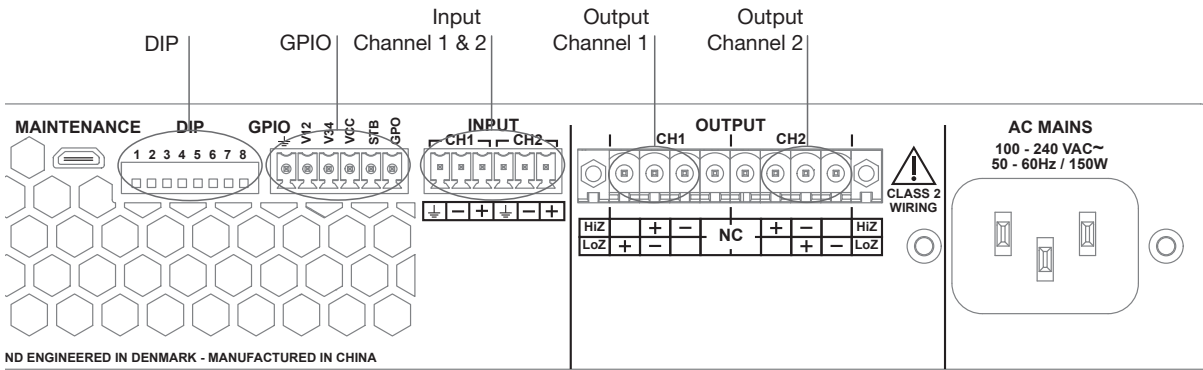

PowerZone 252

- Amplifiers will not switch on from standby mode unless an input signal is present.

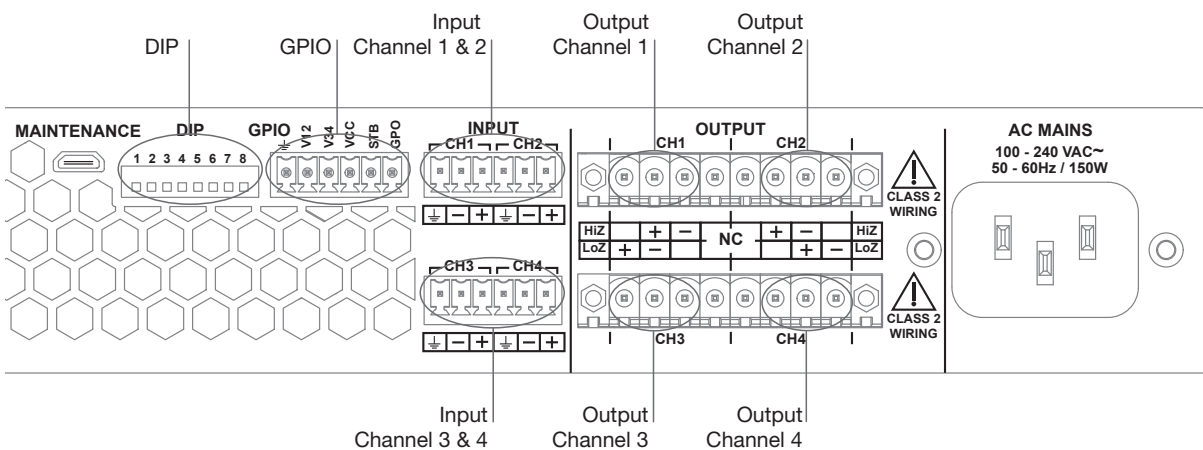

PowerZone 1004 and 504

DIP switch functions

SWITCH	OFF↓	ON↑
1	Channel 1 in Low-Z mode	Channel 1 in Hi-Z mode
2	Channel 2 in Low-Z mode	Channel 2 in Hi-Z mode
3	Channel 3 in Low-Z mode (Not used on two channel amplifier)	Channel 3 in Hi-Z mode (Not used on two channel amplifier)
4	Channel 4 in Low-Z mode (Not used on two channel amplifier)	Channel 4 in Hi-Z mode (Not used on two channel amplifier)
5	70V Hi-Z mode (for channels in Hi-Z mode)	100V Hi-Z mode (for channels in Hi-Z mode)
6	Input ganging 1: All	Input ganging 1:1
7	GPIO standby polarity NO (Normally Open)	GPIO standby polarity NC (Normally Closed)
8	Front panel control unlocked.	Front panel control locked.

Mounting Ventilation

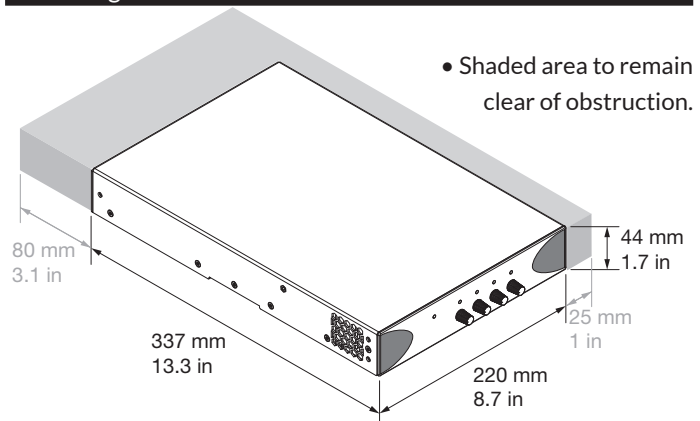

- Ensure that rack or other confined installation does not restrict the airflow required for safe and reliable operation of the equipment.

- If this equipment is operated in a confined installation, the internal ambient operating temperature may exceed the external ambient temperature. It is important to ensure that the maximum operating temperature for the equipment is not exceeded.

This symbol is intended to alert the user to the presence of uninsulated "dangerous voltage" within the product's enclosure that may be of sufficient magnitude to constitute a risk of electric shock to persons.



WARNING!
DO NOT EXPOSE THIS EQUIPMENT
TO RAIN OR MOISTURE.



This symbol is intended to alert the user to the presence of important operating and maintenance (servicing) instructions in the literature accompanying the appliance.

Ce symbole a pour but d'attirer l'attention de l'utilisateur sur la présence, à l'intérieur du boîtier de l'appareil, d'une « tension dangereuse » non isolée, qui pourrait être suffisamment puissante pour représenter un risque d'électrocution pour les personnes.

AVIS
RISQUE DE CHOC
ELECTRIQUE.
NE PAS OUVRIR

CAUTION
RISK OF ELECTRIC SHOCK
DO NOT OPEN

Ce symbole a pour but d'attirer l'attention de l'utilisateur sur la présence, dans la documentation qui accompagne l'appareil, d'instructions importantes relatives à son utilisation et sa maintenance (entretien).

This equipment must be earthed.

Important Safety Instructions

1. Read these instructions.
2. Keep these instructions.
3. Heed all warnings.
4. Follow all instructions.
5. Do not use this apparatus near water.
6. Clean only with a dry cloth.
7. Do not block any ventilation opening. Install in accordance with the manufacturer's instructions.
8. Do not install near any heat sources such as radiators, heat registers, stoves, or other apparatus (including amplifiers) that produce heat.
9. To reduce the risk of electrical shock, the power cord shall be connected to a mains socket outlet with a protective earthing connection.
10. Do not defeat the safety purpose of the polarized or grounding type plug. A polarized plug has two blades with one wider than the other. A grounding type plug has two blades and a third grounding prong. The wide blade or the third prong are provided for your safety. If the provided plug does not fit into your outlet, consult an electrician for replacement of the obsolete outlet.
11. Protect the power cord from being walked on or pinched particularly at plugs, convenience receptacles, and the point where they exit from the apparatus.
12. Do not unplug the unit by pulling on the cord, use the plug.
13. Unplug this apparatus during lightning storms or when unused for long periods of time.
14. Refer all servicing to qualified service personnel. Servicing is required when the apparatus has been damaged in any way, such as power supply cord or plug is damaged, liquid has been spilled or objects have fallen into the apparatus, the apparatus has been exposed to rain or moisture, does not operate normally, or has been dropped.
15. The appliance coupler, or the AC Mains plug, is the AC mains disconnect device and shall remain readily accessible after installation.

Consignes de sécurité importantes

1. Veuillez lire ces instructions.
2. Conservez ces instructions.
3. Respectez tous les avertissements.
4. Suivez toutes les instructions.
5. N'utilisez pas cet appareil près de l'eau.
6. Nettoyez uniquement avec un chiffon sec.
7. N'obstruez pas les ouïes de ventilation. Installez l'appareil en respectant les instructions du fabricant.
8. Éloignez l'appareil des sources de chaleur : radiateurs, bouches de soufflage, fours et autres (y compris les amplificateurs).
9. Pour réduire le risque d'électrocution, le cordon d'alimentation doit être connecté à une prise de courant avec une mise à la terre de protection.
10. Respectez le dispositif de protection de mise à la terre de la prise secteur. Une prise polarisée est équipée de deux fiches, l'une plus large que l'autre. Une prise avec borne de terre est équipée de deux fiches et d'une borne de terre. La fiche large, ou la borne de terre, est garante de votre sécurité. Si la fiche secteur fournie avec l'appareil ne correspond pas à la prise secteur de votre installation, faites remplacer cette dernière par un électricien.
11. Disposez les câbles de sorte qu'ils ne puissent pas être piétinés, coincés ou pincés ; une attention toute particulière doit être accordée au niveau des prises secteur et de l'embase secteur de l'appareil.
12. Ne débranchez pas l'appareil en tirant sur le cordon. Utilisez la fiche.
13. Débranchez cet appareil du secteur lors des orages ou des longues périodes d'inutilisation.
14. Confiez toute réparation à un technicien qualifié. L'intervention d'un technicien est nécessaire dans les cas suivants : le cordon d'alimentation ou la prise secteur sont endommagés, des corps étrangers ou du liquide se sont introduits dans l'appareil, l'appareil a été exposé à la pluie ou à l'humidité, l'appareil montre des signes de dysfonctionnement ou est tombé.
15. Le coupleur de l'appareil, ou la fiche secteur, est le dispositif de déconnexion du secteur et doit rester facilement accessible après l'installation.

FCC Compliance

This device complies with part 15 of the FCC Rules. Operation is subject to the following two conditions:

1. This device may not cause harmful interference.
2. This device must accept any interference received, including interference that may cause undesired operation.

Note: This equipment has been tested and found to comply with the limits for a Class B digital device, pursuant to part 15 of the FCC Rules. These limits are designed to provide reasonable protection against harmful interference in a residential installation. This equipment generates uses and can radiate radio frequency energy and, if not installed and used in accordance with the instructions, may cause harmful interference to radio communications.

However, there is no guarantee that interference will not occur in a particular installation. If this equipment does cause harmful interference to radio or television reception, which can be determined by turning the equipment off and on, the user is encouraged to try to correct the interference by one or more of the following measures:

- Reorient or relocate the receiving antenna.
- Increase the separation between the equipment and receiver.
- Connect the equipment into an outlet on a circuit different from that to which the receiver is connected.
- Consult the dealer or an experienced radio/TV technician for help.